

P/N: 9197023**DESCRIPTION**

The Pressure Switch can be used in place of microswitches to open or close electrical circuits to:

- Sound an alarm
- Trip a magnetic contact to turn off the electrically operated cooking appliance
- Operate an Electric Gas Valve
- Shut off exhaust fans

There is no limit to the quantity of Pressure Switches in a Kidde® system.

The Pressure Switch is screwed on the upper end of the 12-inch (305 mm) length of vertical 1/2-inch (13 mm) black pipe (riser).

The vertical riser is fastened to a tee which may be located wherever convenient in the discharge pipe. The piping used to plumb the pressure switch must be included in the total volumetric calculation for the overall discharge piping and individual branch line. The purpose of the riser is to provide an air cushion during discharge to prevent the entrance of Wet Chemical into the Pressure Switch. The switch is a SPDT rated 15 Amps, 115/230 Vac; 5 Amps at 28 Vdc; 1/2 Amp at 125 Vdc, and 1/4 Amp at 250 Vdc. Electrical appliances usually have a higher amperage rating than 15 Amps and must not be wired directly to the Pressure Switch. A magnetic contact or relay must be used.

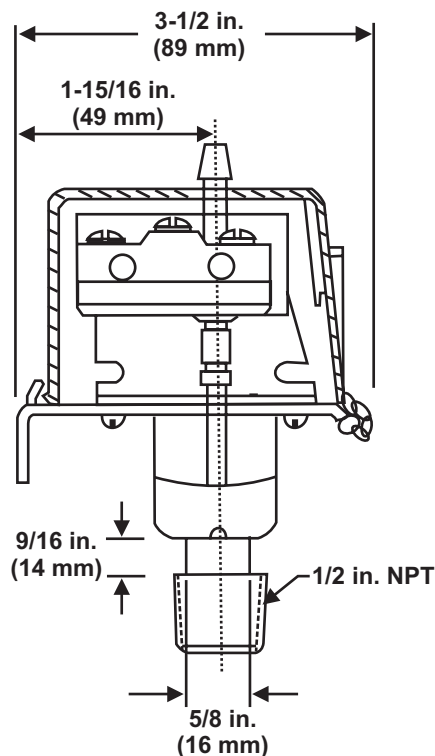

This literature is provided for informational purposes only. KIDDE-FENWAL, INC. assumes no responsibility for the product's suitability for a particular application. The product must be properly applied to work correctly. If you need more information on this product, or if you have a particular problem or question, contact KIDDE-FENWAL, INC., Ashland, MA 01721. Telephone: (508) 881-2000.

Kidde Fire Systems
A UTC Fire & Security Company
400 Main Street
Ashland, MA 01721
Ph: 508.881.2000
Fax: 508.881.8920
www.kiddefiresystems.com